

The TP-82 wireless thermostat

The TP-82 thermostat can be used to set and measure the temperature in a room. Temperature adjustment can be performed very simply by turning the setting knob. This knob can be locked to avoid accidental settings. It has anti-freeze protection and when combined with an Oasis wireless security system (Jablotron), the following are possible:

- Switching the heating ON and OFF remotely (by mobile phone, remote control or Internet).
- Disabling the heating when windows are open.
- Informing the user about heating faults and frost threats (if the temperature drops below a pre-configured value a warning SMS is sent).
- Informing on the occurrence of fire (when the temperature is above a pre-configured value).

The thermostat is battery-powered. The main advantage is that there is no need for a cable between the thermostat and the heating system.

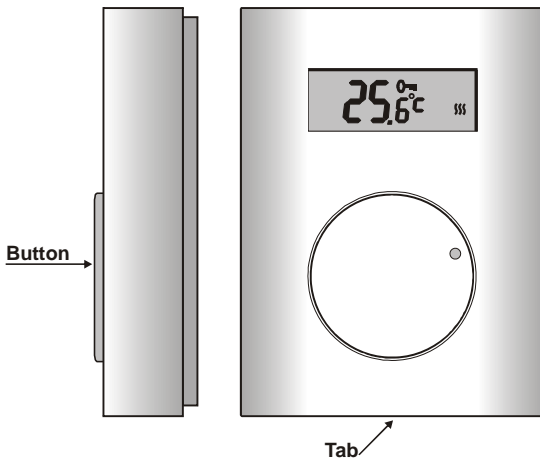

Installation

The TP-82 should be mounted in a dry indoor location. Choose a mounting location about 1.5 meters above the floor in an area with good air circulation. Avoid places with draughts, dead air spots and radiant heat from the sun or appliances. It should not be installed close to any metal structure or other objects that may obstruct radio signal transmissions.

1. Release the upper cover by pressing the plastic tab on the bottom side of the housing
2. Mount the back part on to the desired location.
3. If the thermostat was purchased as a kit along with a receiving unit, connect the detector's battery (pull out the red tape to activate the battery). Otherwise see section "Mounting the receiving unit"
4. Close the thermostat.

Mounting the receiving unit

Install and connect the receiving unit to the heating system. If the receiving unit was purchased separately then the thermostat must be enrolled to it – enter enrollment mode on the receiving unit (see its manual) and connect the battery to the thermostat.

Configuring the fixed parameters

The thermostat works with the following 4 temperature thresholds: **t Hi** (comfort), **t Lo** (economic), **ALHi** and **ALLo** (fire/freeze). Each of the parameters is configurable within a corresponding temperature range – see the table below.

You can enter the adjustment menu by keeping the knob pressed for 10 seconds. Scrolling the menu is done by turning the knob. The display will show temperature parameter names – see the table below. The currently displayed parameter can be adjusted by pressing the knob briefly, turning the knob until the desired temperature is displayed, and confirming the setting by re-pressing the knob (this will also cause a return to the menu so that you can configure other parameters immediately). The adjustment menu is escaped from by pressing the knob while **OK** is displayed or automatically after 30 seconds. The parameter ranges are restricted according to the table.

Parameter	Adjustment range	Factory	Description
SPAN	0.1°C;0.2°C;0.5°C	0.2°C	Hysteresis for switching
t Lo	+6°C to +40°C*	6°C	Economic temperature
t Hi	+6°C to +40°C*	40°C	Comfortable temperature
ALLo	-9°C to +20°C	3°C	Panic alarm
ALHi	+30°C to +70°C	60°C	Fire alarm
Corr	±1°C	0	Correction

* Ranges **t Lo** and **t Hi** must not overlap

Adjustment ranges as depicted on a coordinate axis:

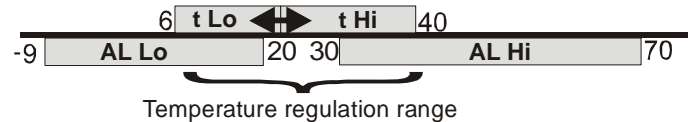

Temperature accuracy adjustment: The thermostat allows you to configure the hysteresis – the accuracy to which the temperature is regulated. The setting is done via the **SPAN** item in the adjustment menu (proceed the same way as with threshold parameters mentioned above). Turning the knob lets you select one of the following accuracy ranges: ±0.1°C, ±0.2°C or ±0.5°C (the factory default setting is ±0.2°C).

Example: If the accuracy is adjusted to ±0.5°C and the temperature is set to 24°C, the thermostat switches the heating on when the temperature drops below 23.5°C and it switches it off if the temperature goes above 24.5°C. In reality the temperature scatter can be slightly higher because of the temperature persistence of the room.

Warning: too high an accuracy can cause the heating to turn on and off too frequently.

Temperature measurement correction: Possible temperature measurement offsets can be corrected via the **Corr** item in the adjustment menu. The range of adjustable corrections is ±1°C.

Instantaneous operation

- When not being handled, the thermostat shows the current temperature in the room.
- **By turning the knob the desired temperature can be set from t Lo to t Hi** (during setting, a hand symbol is shown on the display). If the temperature cannot be set, see "Locking the thermostat".
Setting the **t Lo** and **t Hi** limits allows the installer to prevent the regulated temperature from being set to undesirably high or low values by instantaneous operation.
Example: If $t Lo = +15°C$ and $t Hi = +22°C$ then the regulation temperature can only be set within the range of +15 to +22°C (unless the adjustment menu is entered).
- If you stop turning the knob the current temperature in the room will be displayed again (3 seconds after the last movement of the knob).
- If the **current temperature is lower than the desired temperature minus the hysteresis**, the thermostat will switch the heating on (a symbol of wavy lines will appear on the display).
- If the **current temperature is higher than the desired temperature plus the hysteresis**, the thermostat will switch the heating off (the symbol of wavy lines will disappear).

Displaying the set temperature

As mentioned above, normally the thermostat displays the current temperature in the room. If you want to display the set temperature, **press the knob briefly** (no matter if the thermostat is locked). The set temperature will then flash on the display for 3 seconds.

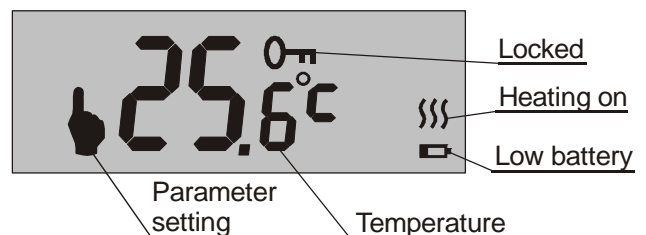

Locking the thermostat

- To prevent the accidental changing of the set temperature the thermostat can be **locked by pressing and holding the knob** (for about 2 seconds, the lock symbol will appear on the display).
- To unlock the thermostat simply **press and hold the turning knob** (for about 2 seconds, the lock symbol will disappear on the display).

Integration into the OASIS system

- The thermostat can also be **enrolled to a control panel as a detector**. If the temperature decreases below **ALLo** a **panic alarm** will be triggered = **frost threat** (heating failure).
- If the temperature exceeds **ALHi** then a **fire alarm** will be triggered.
- An AC-82 receiving unit has two output relays (X and Y). TP-82 thermostats can be enrolled separately to each relay (in enrollment mode 4) in order to **control two independent heating circuits**.
- **To operate a heating system the Oasis control panel** can also be enrolled (sequence 299) to the same relay as the thermostat is enrolled to. A thermostat enrolled to the X relay **can be operated via the PGX programmable output**, and a thermostat enrolled to the Y relay operated via **PGY**. If the programmable **output of the control panel is switched on**, the thermostat maintains the set temperature. If the control panel's output is **switched off** the thermostat only triggers heating if the temperature drops **below InLo** (anti-freeze protection).
- **To operate the heating, RC-80 or RC-88 remote controls** can also be enrolled to a receiving unit (AC-82). The heating can be **switched on** by remote controls to heat to the desired temperature and also **switched off where it only heats when the temperature is below ALLo**.
- **To disable heating when windows are open** JA-80M or JA-82M **detectors** can also be enrolled to the same relay as the thermostat is enrolled to. If the windows are closed it **heats** to the desired temperature and if windows are open it **heats only when temperature is below ALLo**.
- **Up to 8 thermostats** can be enrolled to a single relay. If at least one thermostat transmits a heat command then the relay will be switched on.

Battery replacement

Replace the battery when the low-battery symbol is displayed (or the thermostat stops working). If the thermostat is enrolled to the control panel, then a low battery will be indicated by the control panel (to the user and installer). Use only AA 1.5V alkaline batteries.

RESET

The RESET function allows you to reset the device to factory defaults listed in the table. You can perform RESET by selecting **Res** in the adjustment menu and pressing and holding the knob for 5 seconds.

Specification

Power supply:	1x AA 1.5 V alkaline battery
Battery lifetime	typically 1 year
Temperature measurement:	+6°C to +40 °C
Temperature accuracy:	adjustable: ± 0.1, ± 0.2 or ± 0.5 °C
Freeze alarm (panic transmission) temperature threshold:	<ALLo configurable from -9°C to +20°C
Fire alarm temperature threshold:	>ALHi configurable from 30°C to 70°C
Operational frequency:	868 MHz, Oasis protocol
Operational radio range:	up to 100 m (open area)
Operational temperature range:	-10°C to + 70°C (low humidity)
Dimensions:	65 x 88 x 20 mm
Can be operated according to	VO-R/10/05.2006-22



Jablotron Ltd. hereby declares that the TP-82 is in compliance with the essential requirements and other relevant provisions of Directive 1999/5/ES. The original of the conformity assessment can be found on the web site www.jablotron.com, Technical Support section.



Note: Dispose of batteries safely depending on battery type and local regulations. Although this product does not contain any harmful materials we suggest you return the product to the dealer or directly to the manufacturer after use.

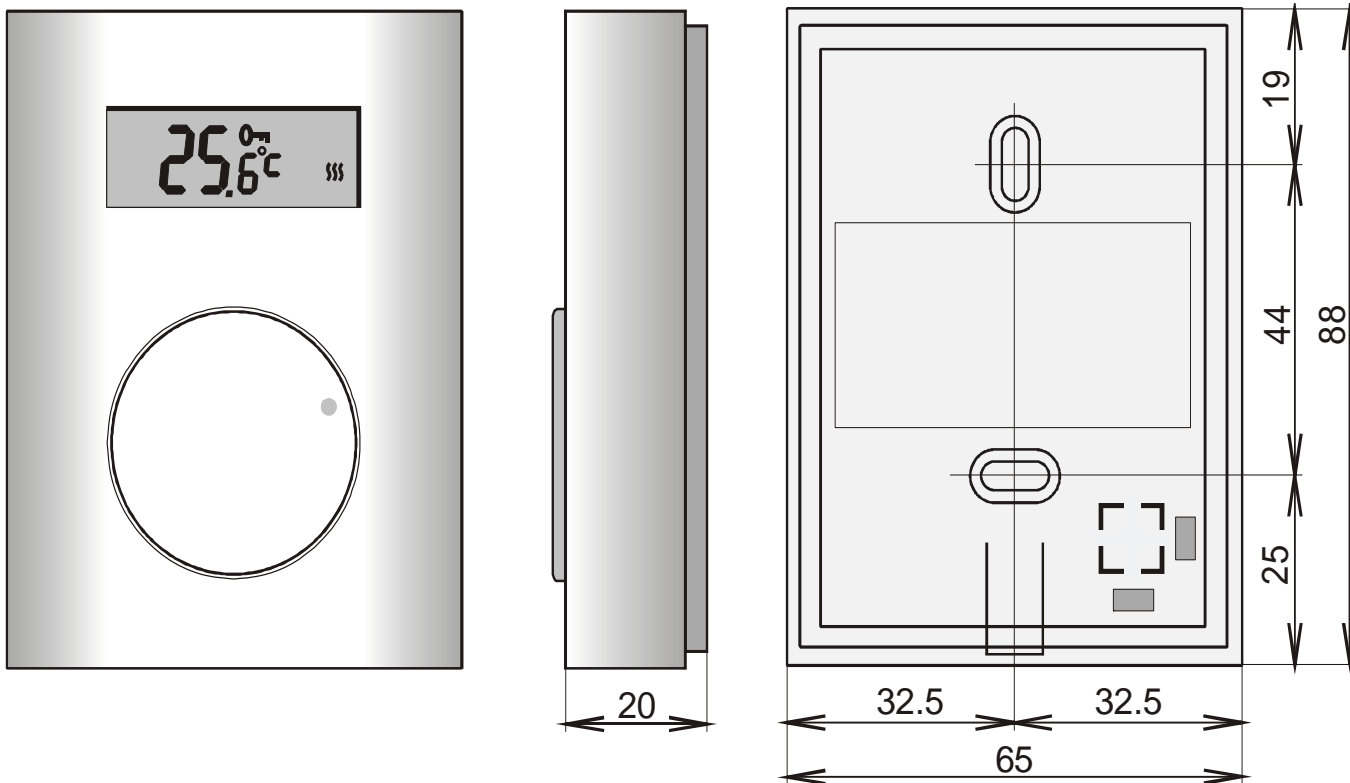

Pod Skalkou 33
466 01 Jablonec nad Nisou
Czech Republic
Tel.: 483 559 911
fax: 483 559 993
Internet: www.jablotron.com